



WLINK

User Manual

---Apply to RT620 4G/3G RTU

V1.6
<http://www.wlink-tech.com>
Feb 2026



Copyright © Shenzhen WLINK Technology Company Limited 2012 ~ 2026

Without our written approval, anyone can't extract, copy whole or part of content of this file and can't spread out in any format.

Caution

Due to product updates or functional upgrading, we may renew the content of this file, and this file only for reference. All statement, information, suggestion .etc in this file do not compose any form of guarantee and we WLINK reserves the right of final explanation.

Shenzhen WLINK Technology Company Limited

Add: 2A, F5 Building, TCL International E City, No.1001 Zhongshanyuan Rd.,
Nanshan Dist., Shenzhen, 518052, China

Web: <http://www.wlink-tech.com>

Service Email: support@wlink-tech.com

Phone: 86-755-86089513

Fax: 86-755-26059261

Contents

1 Product Introduction	1
1.1 Product Overview	1
1.2 Product Appearance	1
1.3 Equipment configuration and accessories	2
1.4 Functional Features	2
1.5 Technical indicators and specifications	4
2 Hardware Installation	6
2.1 Prepare	6
2.2 Product Interfaces	7
2.3 Power Supply	10
2.4 LED status	10
3 RTU Configuration	11
3.1 Web configuration environment	11
3.2 System Status	12
3.3 Modbus RTU	13
3.4 Basic Network	15
3.4.1 WAN	15
3.5.2 Cellular Setting	16
3.5 LAN	18
3.6 WLAN Configuration (Wi-Fi)	19
3.6.1 Basic Settings	19
3.6.2 Wireless Survey	21
3.7 Administration	21
3.7.1 Scheduled Reboot	21

3.7.2 Time	22
3.7.3 Log	23
3.7.4 Admin Access	23
3.7.5 Upgrade	24

1

Product Introduction

1.1 Product Overview

RT620 is an intelligent acquisition and transmission terminal device that focuses on the acquisition, data processing, and transmission of cellular connections. The device supports various analog signal sensors, switch signal sensors and RS485 communication interface; supports GNSS/Beidou positioning acquisition and transmits location information through 3G/4G mobile network.

The built-in temperature sensor allows users to better collect and judge the ambient temperature.

Rechargeable built-in clock battery supports power-down operation of the real-time clock.

Rich interface resources can cater to various changing and complex market application scenarios.

1.2 Product Appearance



Front View



Back View

1.3 Equipment configuration and accessories

Accessories are described in Table 1-1.

Accessories name	Quantity	Remark
RT620	1x	None
WIFI Antenna	1x	None
4G Antenna	1x	None
Network Cable	1x	None
Terminal Block	1x	None
Installation Kit	1x	None
Certificate of Conformity	1x	None
Power Adapter	1x	24 V /1A

Table 1-1

1.4 Functional Features

➤ **Basic Features**

- 3G/4G
- RS485, Modbus-RTU Protocol Support, up to 32 devices can be mounted on a single channel.
- DI: Digital signal input: connect to switch signals such as door sensors and smoke detectors
- ADC Input: It can be connected to an external 4~20mA current sensor or a 0~+5V voltage sensor,
- Wide voltage power supply, anti-reverse protection. The power supply range can reach 18V~32V DC; the standard power supply is 24V/1A DC power supply.
- Built-in clock battery
- Local parameter configuration and status viewing through the web page.
- The built-in programmable function is used to collect the analog and switch values of the machine, as well as the data of the Modbus protocol sensor connected to the serial port and control the relay output. Support local data calculation

➤ **Scalability**

- Support GPRS/WCDMA/TDD-LTE/FDD-LTE wireless real-time transmission of regular data
- Support remote parameter setting, modification or reset.

- Support remote firmware upgrade.
- Support Detran M2M terminal remote management protocol.
- Support MQTT protocol, send data to public cloud server.
- Scalable large-capacity data storage (8GB~64GB), common applications can meet at least one month of local data storage.
- Built-in temperature sensor.
- Optional support for GPS or Beidou satellite positioning.
- Support Wi-Fi to expand local applications, handheld terminals can be connected through Wi-Fi or APP to view the status of local devices.

1.5 Technical indicators and specifications

Name	Spec	Remark
Physical properties		
Size	236 X 125 X 40 mm	
Weight	500g	
Operating temperature	-30 ~ 75°C	
Storage temperature	-40 ~ 85°C	
Humidity	0% ~ 95% No condition	
Shock	SAE J1455	
System		
CPU	MIPS32 74K Core. 533MHz/560DMIPs	Up to MIPS32 74K Core. 533MHz/560DMIPs
Flash	8MB	Up to 16MB
RAM	64MB	Up to 128MB
Microprocessor	Cortex M3	
Internal storage	8GB	Up to 64GB
Electrical properties		
Operating Voltage	+18V~+32V DC (Standard 24V/1A power adapter)	Lower than 18V will lead to inaccurate 12V output
Working average power consumption	180mA/24V	4G and Wi-Fi enable
Standby power consumption	100mA/24V	4G and Wi-Fi disable
4G/3G		
Module	Industrial grade	The frequency band needs to indicate the country or region
Frequency	FDD Band1/3/5 TDD Band38/39/40/41 WCDMA 900/2100MHz	
Output	Class4 (2W) @900MHz; Class1 (1W) @1800MHz	
GPRS	Class10	
Communication Protocol	PPP、TCP、UDP、Ping	
Gain	1.4dBi@900MHz, 3dBi@1800MHz	
RF impedance	50Ω	
SIM card	1.8/3V micro-SIM	
Data storage		
Data storage	Expandable to a maximum of 64GB data storage space	Customization, determine the storage time according to the user agreement

Physical interface		
24 Power Input	Power input, support V+, V- reverse connection; Vin=18 ~ 32V	Standard 24V@1A power adapter
24 Power Output	Power output = Vin – 1V; for 24V sensor equipment to take power	Equivalent input power voltage value
+12V Power Output	12V DC output, for 12V sensor equipment to take power	
+5V Power Output	5V DC output, for DI wet contact to take power	
AI	12 channels of analog signal input detection, 12Bit precision	
DI dry contact	12-channel switch signal input detection	
DI wet contact	4 channels 0 - 5V voltage digital signal detection	
The relay		
Communication interface – the wireless communication part can be extended to support		
WAN/LAN	10/100M Ethernet port, can be set as wired WAN port or LAN port	
LAN	10/100M Ethernet port, local area network LAN port	
USB2.0	Can be used for external data storage or encryption, upgrade	
4G Main ANT	4G/3G Main antenna for mobile communication	The corresponding external antenna must be connected
4G Aux ANT	4G/3G Auxiliary antenna for mobile communication	
Wi-Fi	2.4G Wi-Fi Antenna	
GPS/BD	GPS / Beidou Antenna	
SIM	Drawer SIM card slot	
RS485	Support 3 channels RS485 local communication interface, which can be used to connect sensor equipment with 485 interfaces	The default baud rate is 9600
RS232	Support 1 RS232 local communication interface, which can be used for system configuration	The default baud rate is 115200

Table1-2

2 Hardware Installation

2.1 Prepare

Parameter	Instruction
RT620	RT620
USB to Serial Cable	It is used for parameter configuration and debugging and needs to be purchased by the user. It is recommended to buy a superior quality USB-to-serial cable to avoid various problems that are difficult to judge. Not required if the computer has a physical serial port.
RS232/RS485	Need to be purchased by users.
Power	220V AC, used to provide power for RT620 products. For other power environments, please contact our technical support for help.
Serial port debugging software	It is used to assist in debugging RT620, check the running status of RT620 to know whether it is working correctly. You can download general related software from the internet or contact our technical support.
Upgrade the software	It is used to upgrade the program of RT620, or restore the default parameters, which can be downloaded from our website. Note: Under normal circumstances, it is not necessary to upgrade the program and restore the default parameters. Please contact our technical support to confirm the necessity before performing this operation.
Internet	The communication function used to debug RT620 can be realized by using ADSL broadband, or portable mobile access devices such as USB modem.
Business platform	User's own business platform software. In order to facilitate debugging, it is recommended that users connect to the temporary platform of the UDP/TCP test software first, and then change the RT620 to the business platform after the debugging is completed.

Table 2-1

VIN=24V		VIN 24V	VIN 24V	+12V	+12V	+5V	Close 1	COM 1	Open 1
V+	V-	GND	GND	GND	GND	GND	Close 2	COM 2	Open 2
Power Input 18~32V		Power Output				Relay interface			

- Power input: V+, V-, non-polar design, can be connected to positive and negative poles arbitrarily, anti-reverse. The input voltage range is +18V ~ 32V DC, recommend +24V/1A DC power adapter.
- Power output: 2-way VIN output, that is, the output voltage is approximately equal to the VIN input voltage value (the actual voltage is VIN-1.1V); 2-way +12V voltage power output; 1-way +5V voltage power output. The output voltage power supply can directly supply power to external sensors, or to relays for control, or to provide power to 0~5V DI digital signal input devices.
- Relay interface: 2-way relay interface - Close normally closed, COM public node, Open normally open. Small signal relay, support control Max 1A/30V DC; 0.3A/60V DC; 0.5A/125V AC.

b) Power input and output

485 -A1	485 -B1	GND	485 -A2	485 -B2
TX	RX	GND	485 -A3	485 -B3
232			485	

- RS485 interface: supports 3 channels RS485 interface communication, which can be used to directly connect to 485 interface devices, such as sensors or meters. The default baud rate is 9600, and the baud rate range can be configured from 1200 to 57600 through the web page.
- RS232 interface: 1 channel RS232 serial port, the default baud rate is 115200. It is used for local software upgrade or parameter configuration and can also be connected to serial devices for data upload.

c) Digital signal input

DI 1	GND	DI 3	GND	N/O 1	GND	N/O 2	GND	N/O 3	GND	N/O 4	GND	N/O 5	GND	N/O 6	GND
DI 2	GND	DI 4	GND	N/O 7	GND	N/O 8	GND	N/O 9	GND	N/O 10	GND	N/O 11	GND	N/O 12	GND

0-5V digital signal input Digital switch signal access: N/O IN is directly connected to GND or disconnected

- Active digital signal input: 4 channels of active 0~5V digital signal input, the GND of the input signal source and the system GND need to be common ground.

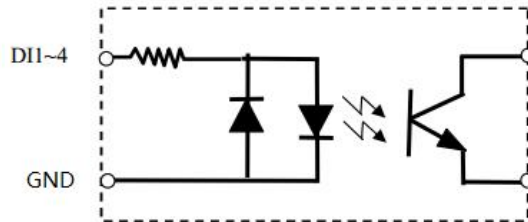

- Passive digital signal input: 12-way passive digital signal input

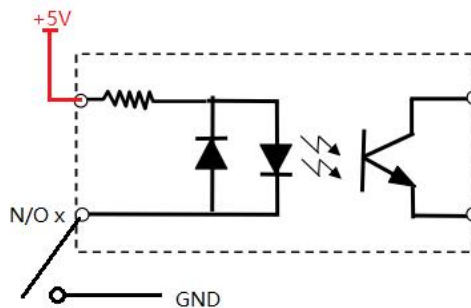

d) Analog signal input

AI 1	AI 3	AI 5	AI 7	AI 9	AI 11	A GND	A GND
AI 2	AI 4	AI 6	AI 8	AI 10	AI 12	A GND	A GND

4-20mA / 0~5V Analog input interface

- 12 channels of analog signal input, the sampling accuracy is 12Bit. It can be connected to 4~20mA power supply type sensor or 0~5V type voltage sensor. The configuration is realized through the programmable window [Note: This step must be operated by a professional!]

2.3 Power Supply

RT620 can be used in complex external environments, usually the power supply range is relatively large, in order to better adapt to the complex application environment and improve the stability of the system, the RT620 power interface is compatible with the DC power socket, which is firm in plugging and unplugging, and stable in use . When RT620 exchanges information with the base station, the instantaneous current changes rapidly and the peak current is large, so the requirement for external power supply is high. RT620 supports +18V~+32V DC power supply.

2.4 LED status

Connect the power cord and check that it is correct, connect the antenna, put in a valid SIM/UIM card, supply power to the RT620 through the power cord, the PWR indicator on the RT620 is on, and judge the status of the RT620 according to Table 2-3.

Status	Description	NET Light	PWR Light
Module self-check	Detect SIM card GPRS/CDMA/WCDMA	100 MS interval on	Always on
Stand By	Waiting to wake up or reconnect	Lights up once every 2 seconds	
Online	Already online	Lights up for 2 seconds and turns off once	
Good signal	The signal field strength is 21 and above	Green	
Poor signal	The signal field strength is 21 and below	Red	

Table 2-3 RT620 LED status

3 RTU Configuration

3.1 Web configuration environment

RT620 supports to be configured by local Ethernet port, you could specify a static IP or set as DHCP. The default IP address is 192.168.1.1, subnet mask is 255.255.255.0, please refer to following.

Step 1 Click “start > control panel”, find “Network Connections” icon and double click it to enter, select “Local Area Connection” corresponding to the network card on this page. Refer to the figure below.

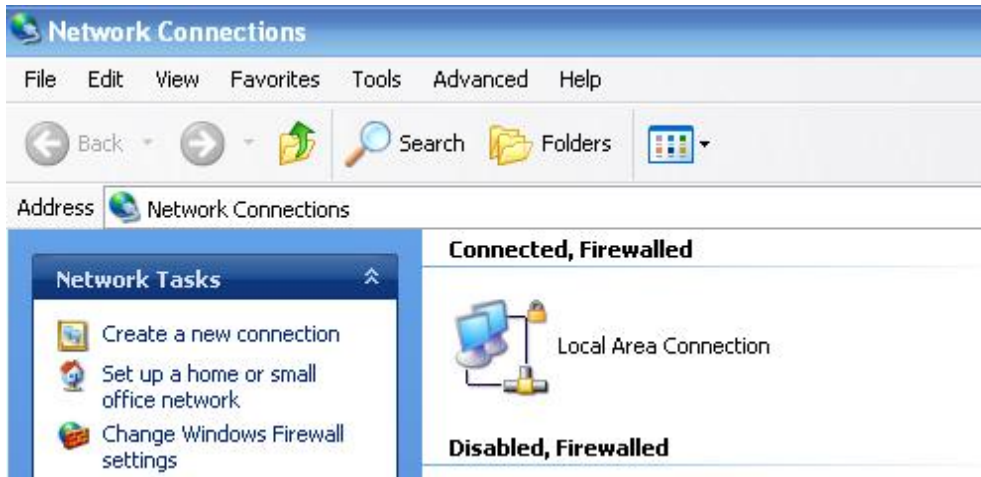
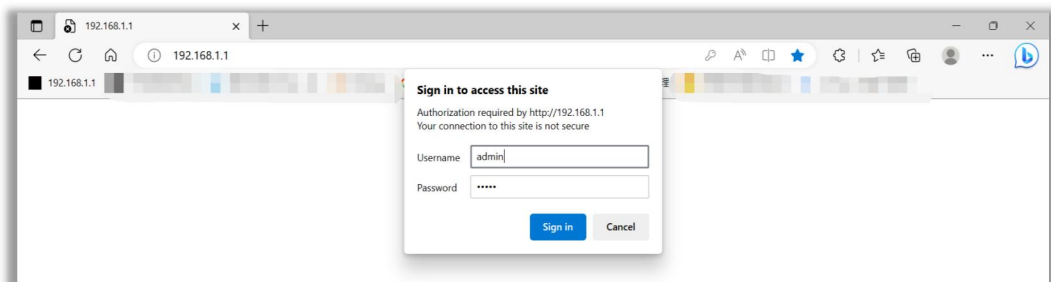

Figure 2-1 Network Connection

Step 2 Obtain a IP address automatically or set up IP address,192.168.1.xxx(XXX can be any number between 2~254)

Step 3 Run an Internet Explorer and visit “<http://192.168.1.1/>”, to enter identify page.



3.2 System Status

By checking the system status, you can get "mobile network status" and "mobile network device information". In this way, you can judged whether the network and equipment are normal according to the relevant status. It is also used to analysis and problem solving of abnormal situations.

Log in to the WEB configuration interface, click System Information, the page is shown below:

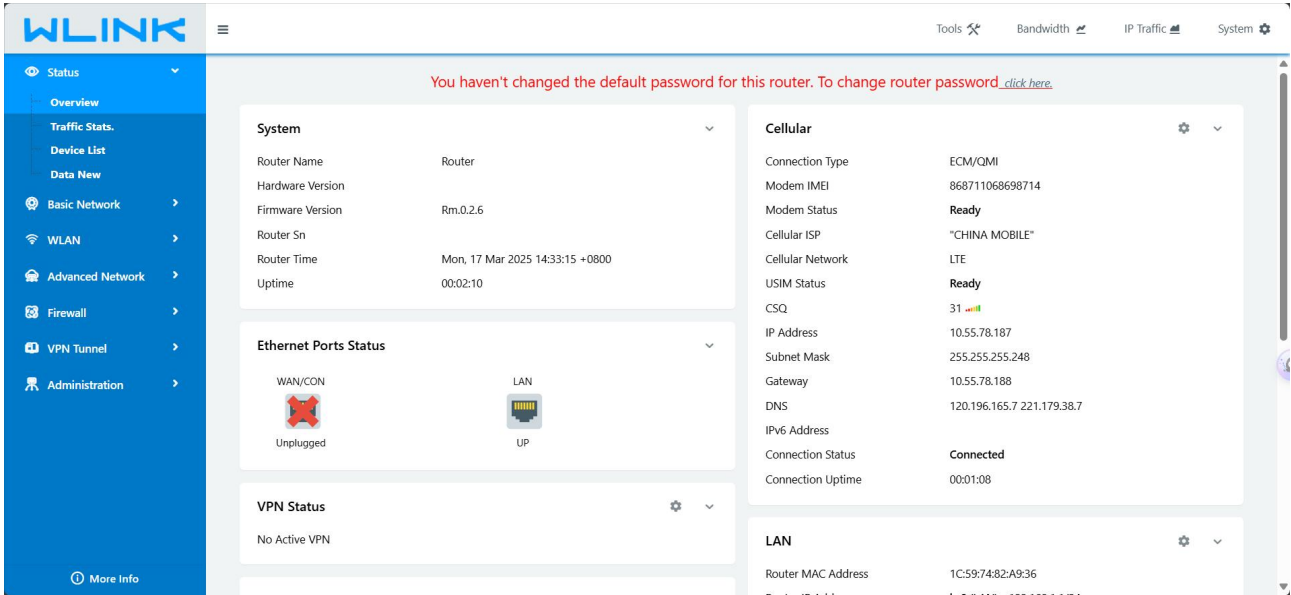

Table 3-1 for the parameter description of overview page:

Parameter	Instruction
Connection Type	Cellular or Wan
Firmware version	version of the current program
Uptime	Display the online duration of the device after dialing up this time
Total/Free Memory	The router's total memory, remaining available memory
MAC Address	Physical address of the device
IMEI	International Mobile Equipment Identity
Modem Status	Check the module connection
USIM Status	Check the SIM card connected
Signal strength	The signal strength of the wireless network. Value range: 1~31
IP Address	The IP address obtained
Subnet mask	Obtained net mask
Gateway	Obtained gateway address.

Connection Status	Including connected and disconnected states
-------------------	---

Table 3-1

3.3 Modbus RTU

Log in to the WEB configuration interface, click the Advanced Network=>Modbus RTU, the page is shown as below:

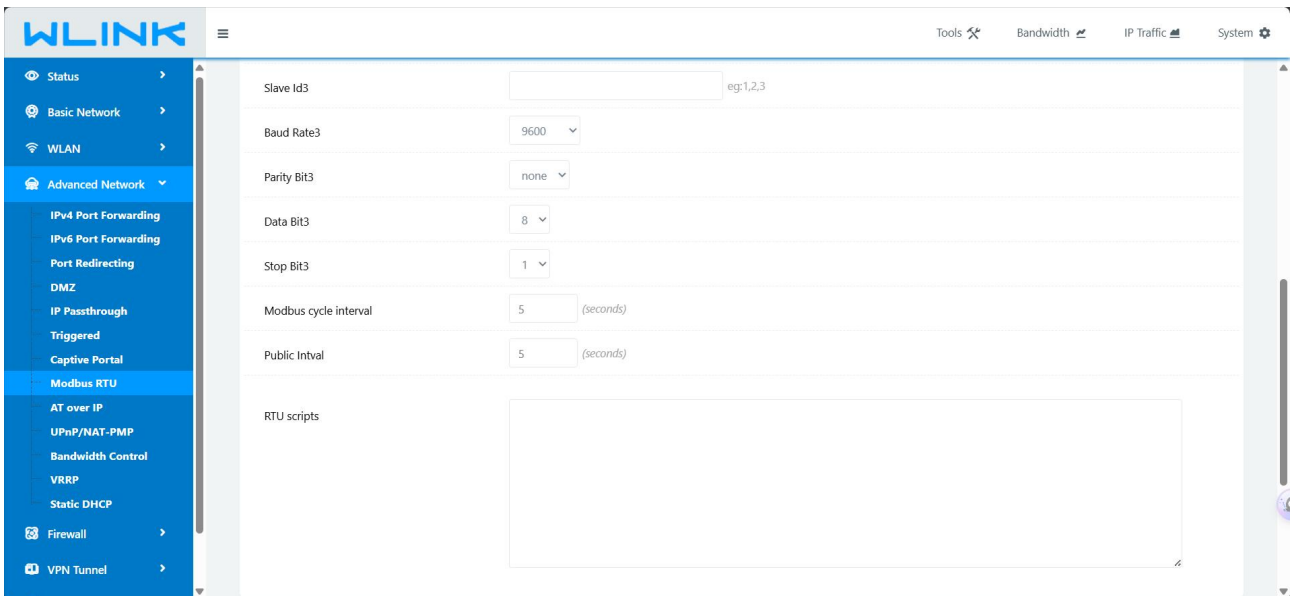
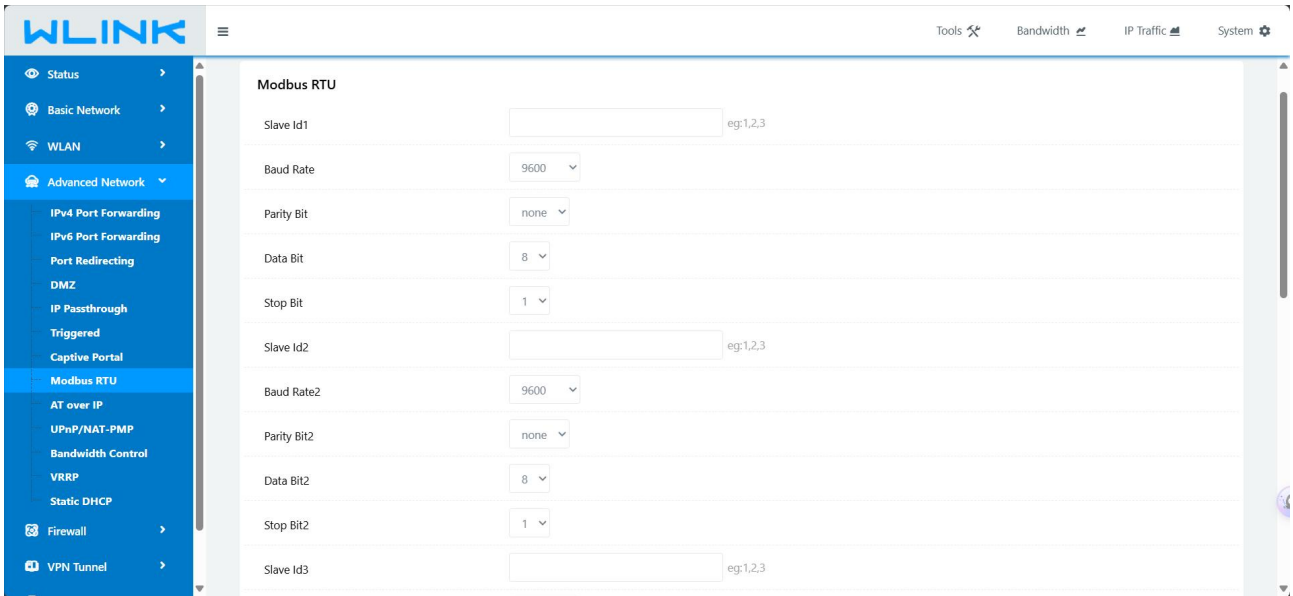

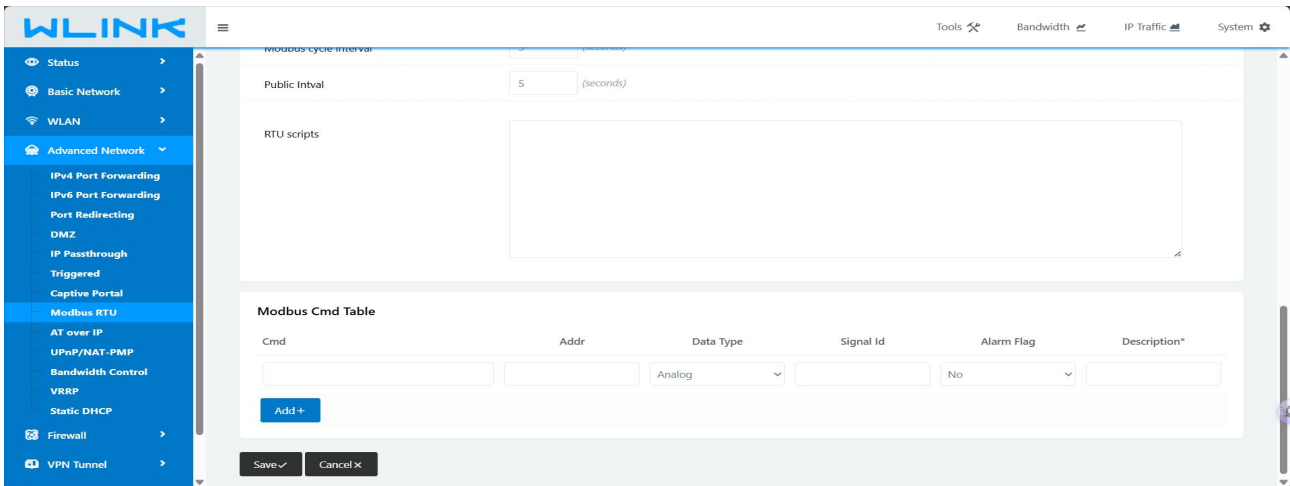

"Modbus RTU" parameters are described in the following table 3-2:

Parameter	Instruction
Slave Id 1/2/3	This configuration item mainly configures the addresses of the connected Modbus slave devices on the three 485 interfaces 1, 2, and 3. Note: The slave addresses connected to each 485 interfaces cannot be repeated.
baud rate/baud rate2/baud rate3	Configure the baud rate of three 485 interfaces
Parity Bit/Parity Bit2/Parity Bit3	Configure the parity bit of three 485 interfaces
Data Bit/ Data Bit 2/ Data Bit 3	Configure the data bit of three 485 interfaces
Stop Bit/ Stop Bit 2/ Stop Bit 3	Configure the stop bit of three 485 interfaces
Modbus cycle interval	The time interval for the master to execute RTU scripts to obtain data.
RTU Scripts	Different scripts need to be written according to different sensors to obtain sensor data.
Modbus Cmd Table	Device obtain data processed by RTU script, using Modbus protocol. Cmd: standard Modbus command, temporarily supports 02 and 04 commands; Addr: register address; Data type: the data type of returned value; Signal ID: the number of the read data; Alarm flag: enable or not; Description: describe the relevant characteristics of the acquired data.

Table 3-2

After the configuration is complete, click the "Save" button. After the configuration is saved, the device will automatically restart to make the corresponding configuration take effect.

Please contact WLINK sales/FAE for script writing and config support.

3.4 Basic Network

3.4.1 WAN

According to the networking situation of the field application, select the Internet connection provided by your ISP from the drop-down menu. The WAN connection type includes the following methods: DHCP, PPPoE, static address. As shown in P 3-7:

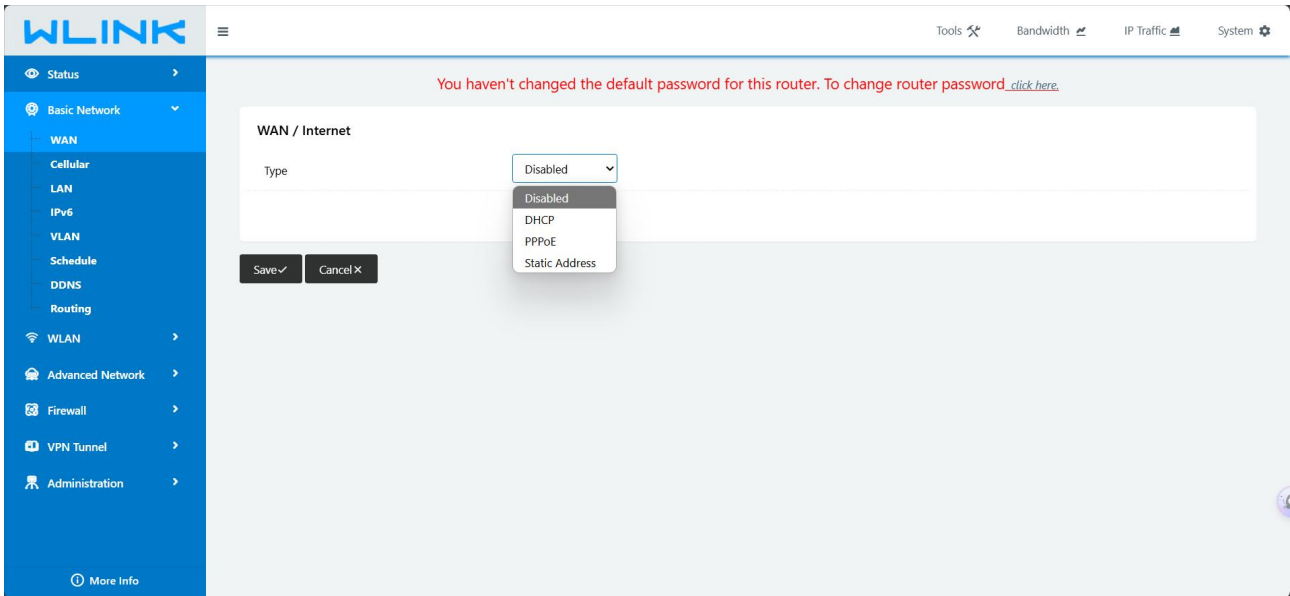

Configure the WAN port connection type, parameter settings Table 3-3:

Parameter	Description	Configuration mode
Type	WAN connection type	Select from the drop-down box, including: 3G/4G: default 4G/3G network Static address: Manually configure the interface IP. If you need to access the Internet through WAN, you need to add gateway, DNS, default route and other configurations in the network connection type. DHCP: DHCP client automatically obtains IP. If you need to access the Internet through WAN, you need to add the default routing configuration in the network connection type. PPPoE: PPPoE dial-up to obtain IP (usually an external ADSL modem for ADSL dial-up Internet access), if you need to access the Internet through WAN, you need to add the default routing configuration in the network type.
IP: Displayed when " Type" is selected as "Static address"		
IP	It needs to be configured when "Connection Type"	It needs to be configured when "Connection Type" is selected as "Static IP".

	is selected as "Static IP".	
Basic settings: Displayed when "Type" is selected as "PPPoE"		
Interface name	The unique identification name of the interface is used for other function calls or when associated with this interface, such as configuring the routing of the interface, controlling the disabling and enabling of the rule interface.	PPPoE non-configurable items. The PPPoE interface name configured on the webpage is specified by the system. Its interface name is: pppoe
Service name	Configuring the PPPoE service name is usually used for identification and judgment between the client and the server, usually provided by the server, and provided by the ISP for ADSL dial-up.	General WORD type, maximum 64 bytes, cannot be empty
Username Password	The username/password used for PPPoE dial-up is usually provided by the server, and it is provided by the ISP for ADSL dial-up.	General WORD type/CODE type, each with a maximum length of 64 bytes, none of which is empty
Bridge WAN port to Primary LAN(br0)	WAN port used as LAN when selected.	

Table 3-3

After the configuration is complete, click the "Save" button to make the configuration take effect.

3.5.2 Cellular Setting

You can modify the relevant parameter according to the application

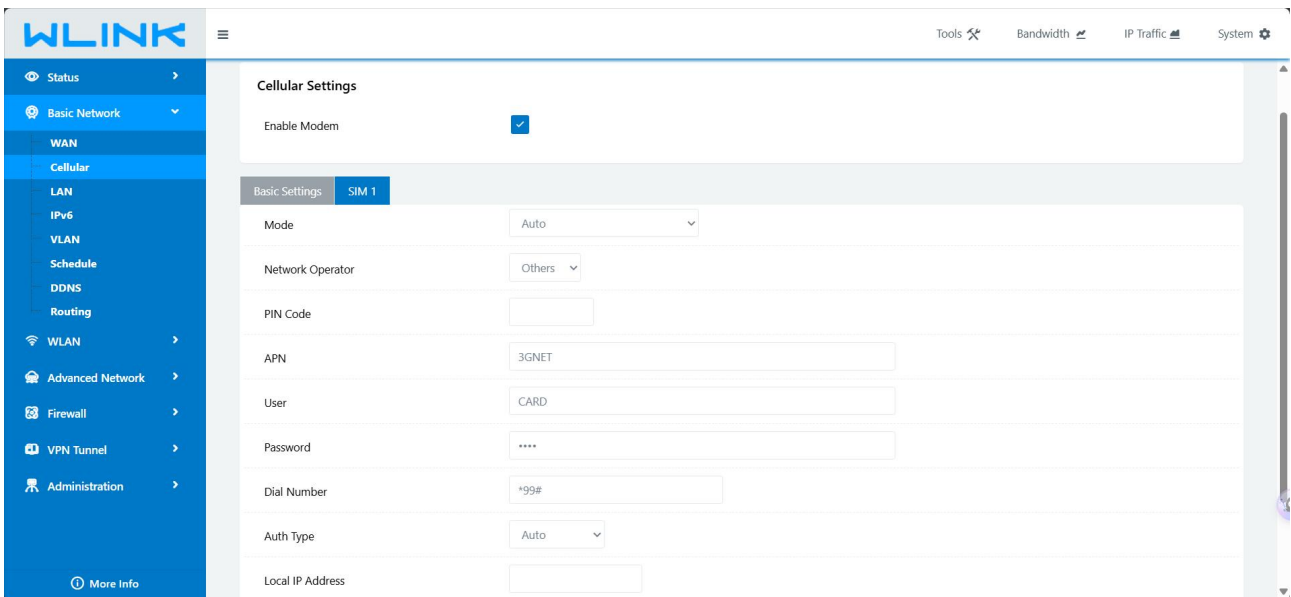
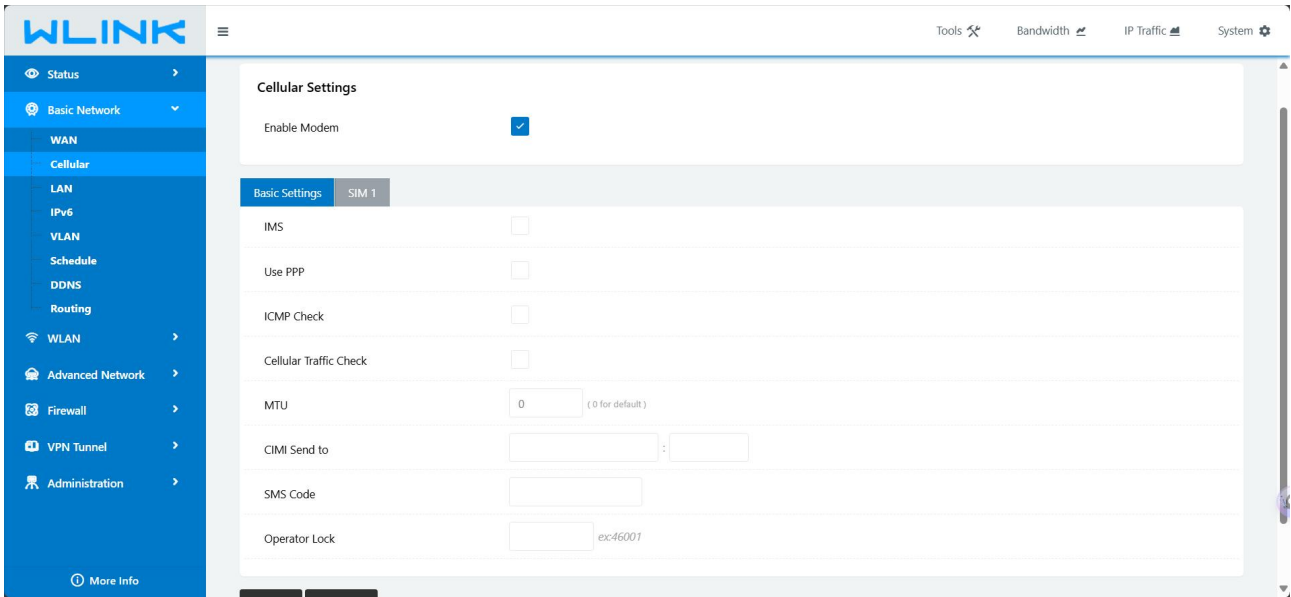

Parameter	Instruction
ICMP check	If enable ICMP check and setup a reachable IP address as destination IP, the router will reconnect/reboot once ICMP check failed.
Cellular Traffic Check	The router will reconnect/reboot once there's no Rx/Tx data.
CIMI Send to	Send CIMI to a defined IP and port by TCP protocol.
SMS Code	Remote control the router by SMS. Only the configured SMS code will work.
Pin Code	Some SIM cards are locked with a Personal Identification Number (PIN) code in case they are lost or stolen
Operator Lock	Lock a specified operator for the router by MCC/MNC code.

Parameter	Instruction
Mode	<p>Auto】 The router will automatically connect to 3G/4G networks and give priority to 4G.</p> <p>【LTE】 Router will connect to 4G only.</p> <p>【3G】 Router will connect to 3G only.</p>
APN	APN is provided by local ISP, usually CDMA/EVDO networks do not need this parameter.
User	SIM card user name is provided by ISP
Password	SIM card password is provided by ISP
Auth. Type	Auto/PAP/Chap/MS-Chap/MS-Chapv2 authentication optional.
Local IP Address	Fix SIM IP. The feature is available if carrier can provide this service.

Table 3-4



NOTE ICMP Check and Cellular Traffic Check are alternative.

【ICMP Check】

Enable ICMP, Router will automatically check whether the defined IP address is reachable per 60s. If the IP address is unreachable and ICMP check is timeout at the first time, it will check 2 times every 3 seconds. If the third time is still failed, the router will redial. The ICMP Check IP is a public IP or company server IP address.

【Cellular Traffic Check】

【Check Mode】 there are Rx(Receive), Tx(Transmission) and Rx/Tx check modes.

【Rx】 Router will check the 3G/LTE cellular receiver traffic. If no receiver traffic within the defined check interval, the router will implement the specified action reconnect or reboot.

3.5 LAN

By viewing the "LAN status" information of RT620, you can know the basic information of the system "LAN status". The specific operation method is as follows:
 Select "Basic Configuration > LAN" in the navigation bar, and in the opened page, you can modify the parameters related to configuring the LAN, as shown below:

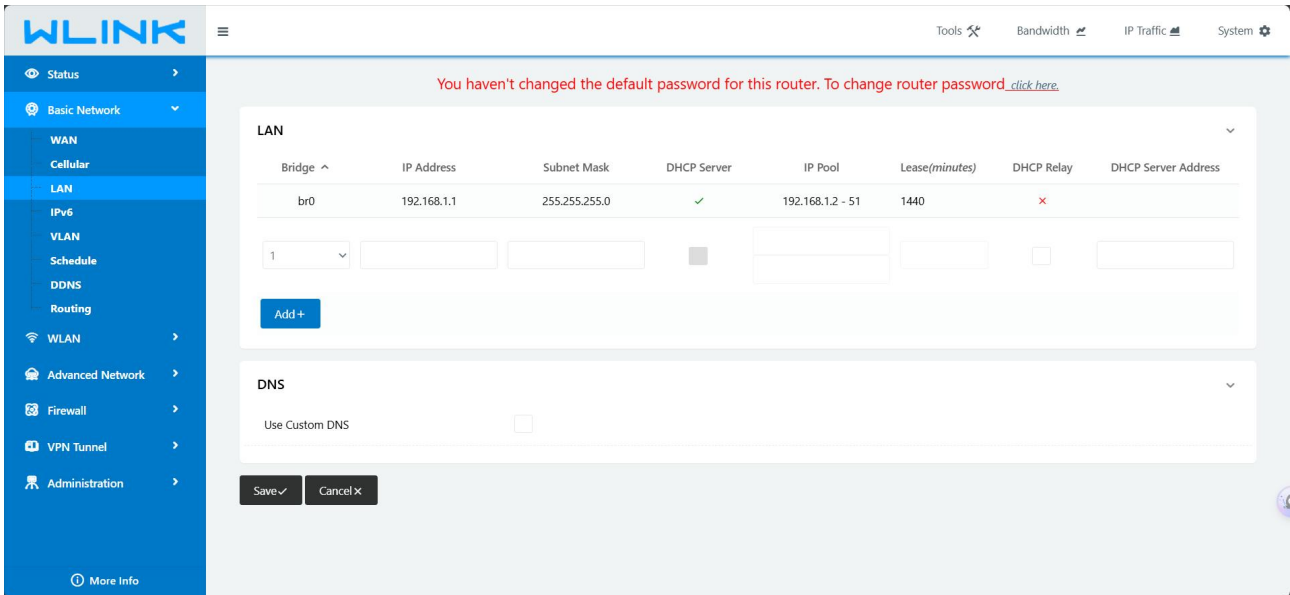

"LAN" configuration parameters are described in Table 3-5:

Parameter	Instruction
Router IP Address	The IP address of the router, the default IP is 192.168.1.1
Subnet mask	The mask address of the router, the default mask is 255.255.255.0
DHCP	Dynamically assign IP services. After the DHCP service is selected, the IP address range and lease options will appear below.
IP Pool	The range of IP addresses in the LAN
Lease	Valid time of IP automatically assigned by DHCP

Table 3-5

After the configuration is complete, click the "Save" button. After the configuration is saved, the device will automatically restart to make the corresponding configuration take effect.

3.6 WLAN Configuration (Wi-Fi)

For RTU series products that support Wi-Fi, you can modify and configure WLAN properties through the Web. The following is an introduction to the common configuration parts of the Wi-Fi part.

3.6.1 Basic Settings

Choose WLAN Configuration > Basic Settings from the navigation bar. In the opened page, you can modify and configure the basic parameters of Wi-Fi.

The factory default setting of the Wi-Fi password is blank, and the user can set or not set the Wi-Fi password according to their own needs. The way to set the Wi-Fi password is: the last item [Security Options] in [Basic Parameter Settings], select the required encryption method from the drop-down list, and fill in the custom Wi-Fi password, save it.

"Basic settings" configuration parameter description.

Parameter	Instruction	Configuration mode
Enable WLAN	Turn on wireless mode. After this item is enabled, the relevant Wi-Fi parameters can be set.	Button selection Enable Disabled
Wireless mode	Select the networking mode of the wireless network	AP working mode is supported by default, and AP+WDS, client, bridge, and pure WDS modes are also supported.
Wireless Network Mode	The router supports multiple protocols such as 11b/g/n.	802.11b only; 802.11g only; B/G mixed
SSID	The ID of the wireless network service set, which is Router by default.	General WORD type, up to 32 bytes, please refer to "Parameter Specification Table" for input specifications.
Channel	The channel used by the wireless network	It is recommended to use the default value.
Channel Width	The channel width used by the wireless network	Support 20MHz and 40MHz
Security Options	Configure the WLAN encryption mode, which can be disabled when encryption authentication is not required. WEP encryption is relatively easy to be cracked, it is recommended to use WPA encryption.	Drop-down box options: WEP; WPA; WPA2

Table 3-6

If need multi SSID servie, you could add it on "MultiSSID" GUI

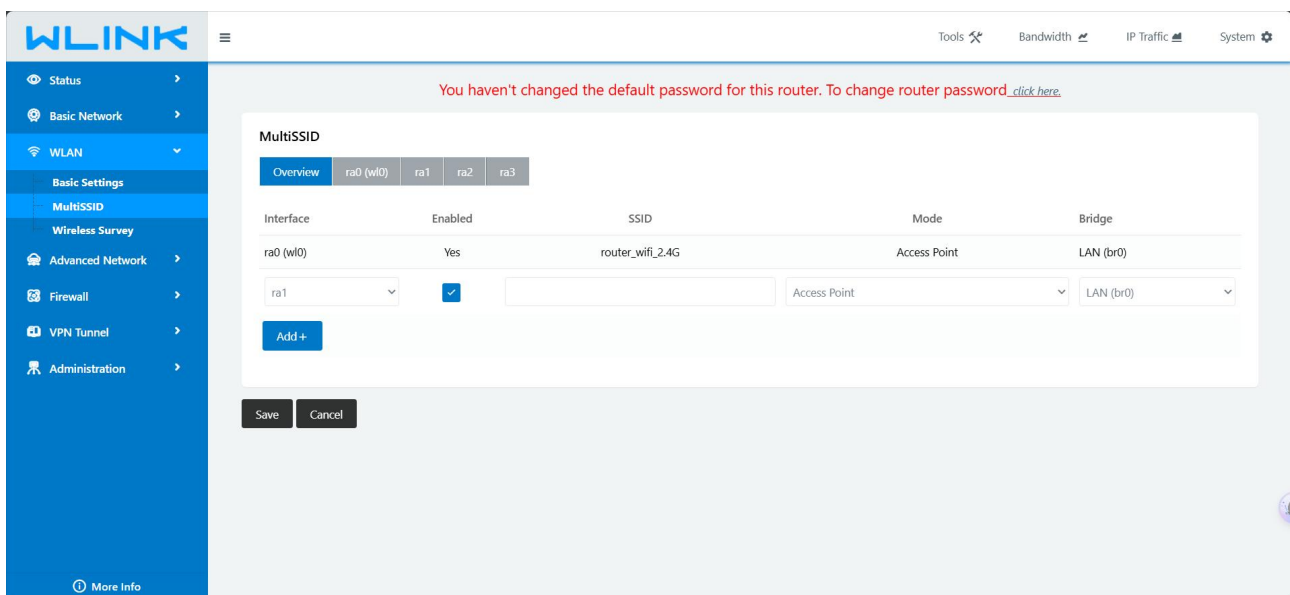

3.6.2 Wireless Survey

Select "WLAN Configuration > Wireless Survey" in the navigation bar. In the opened page, you can search for related parameters of nearby wireless networks.

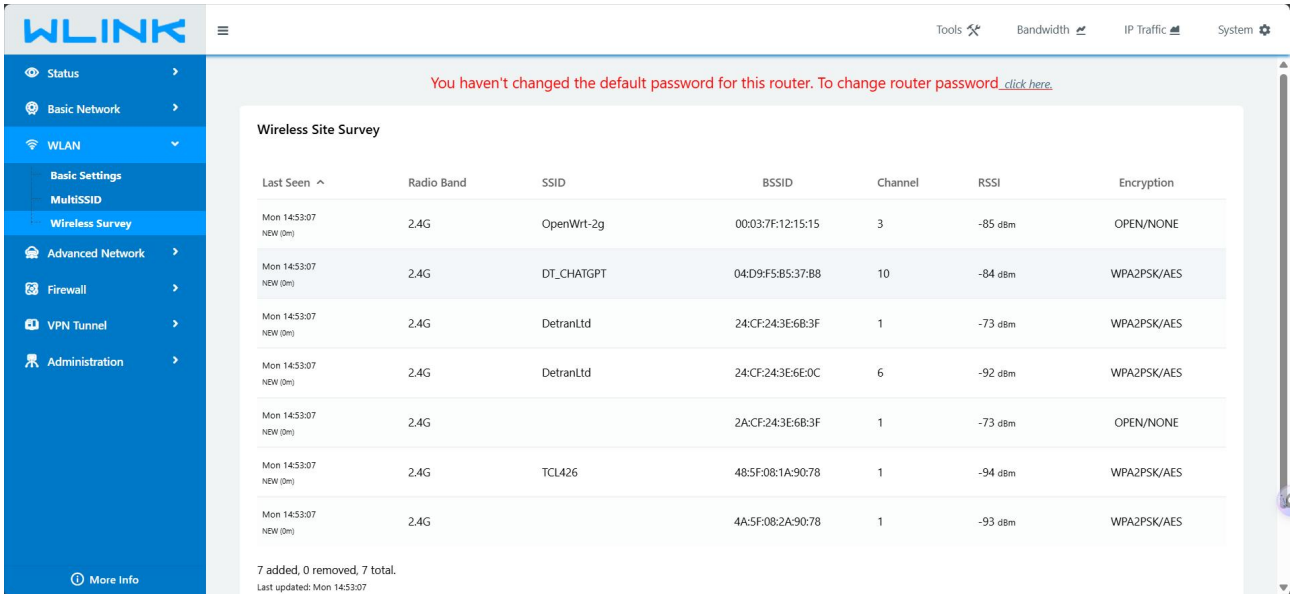

3.7 Administration

3.7.1 Scheduled Reboot

Choose Administration > Scheduled Restart from the navigation tree. In the opened page, you can modify the relevant parameters of the scheduled restart function.

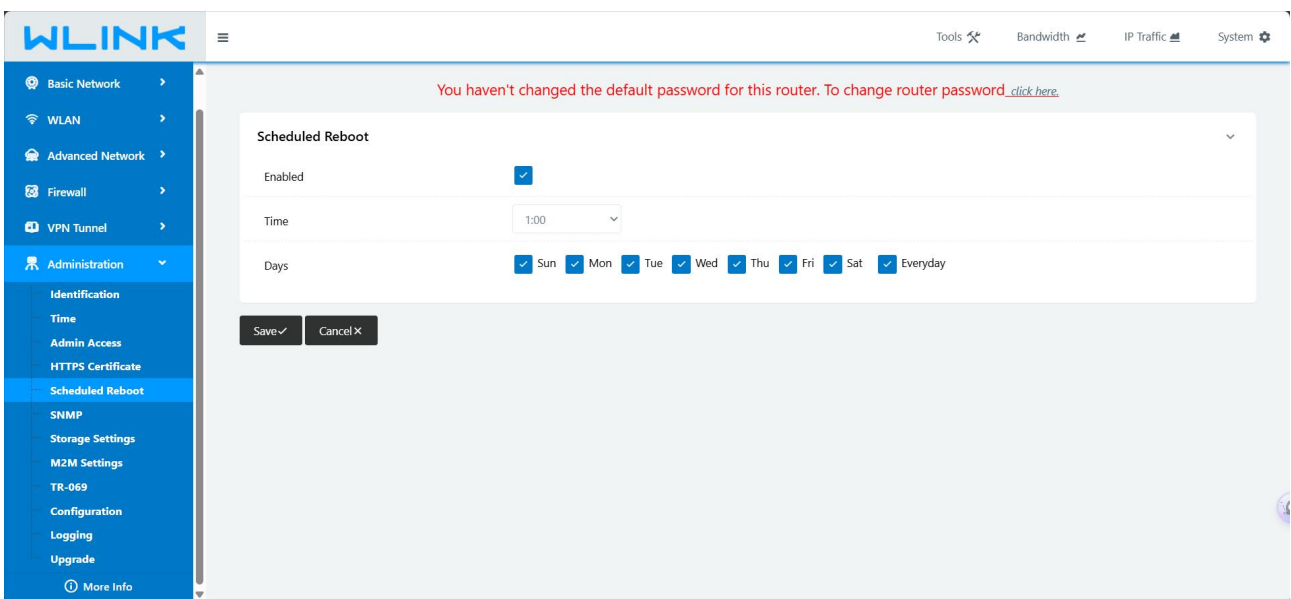

After the configuration is complete, click the "Save " button, and the configuration will take effect.

3.7.2 Time

The RT620 supports NTP (Network Time Protocol) network protocol for time synchronization. Performing NTP network time synchronization can ensure that the system time of the router corresponds to the actual time and can ensure that functions such as task management are executed at the correct time. Specific steps are as follows.

Step 1: Select "Administration > Time".

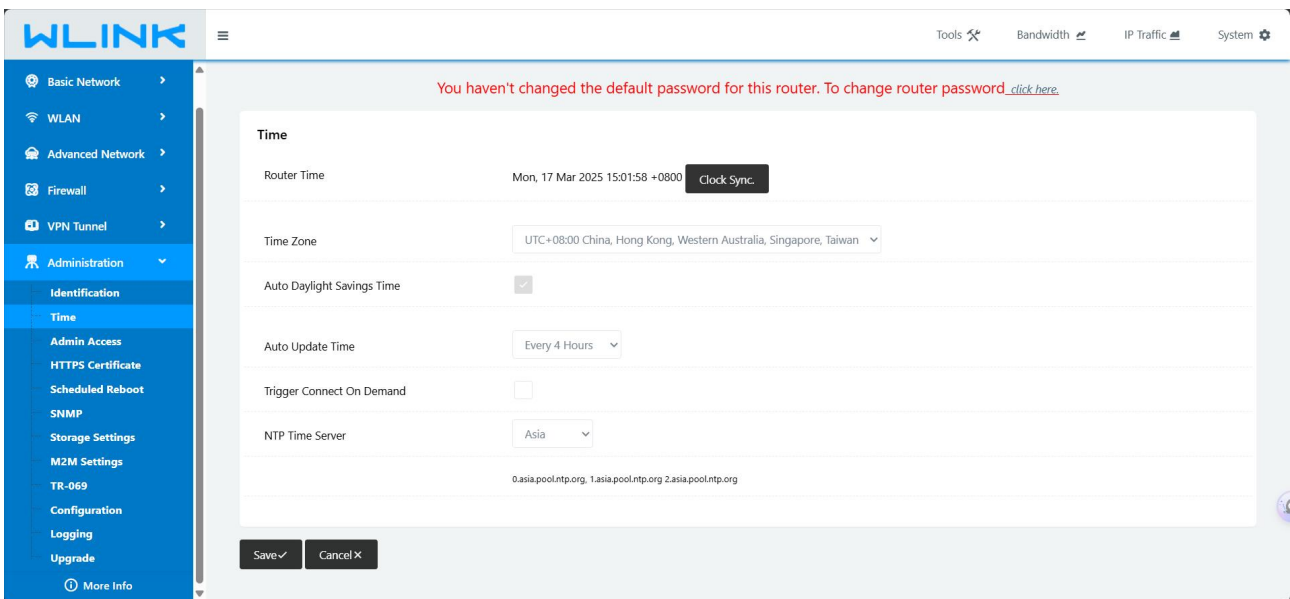

Step 2: Parameter configuration instructions:

Parameter	Instruction	
Time Zone	Time synchronization type for system time verification.	drop-down list box selection.
Auto Update Time	Set the time for automatic synchronization	drop-down list box selection.
Trigger Connect On Demand	Synchronize time only when needed	Enable or Disable
NTP Time Server	NTP clock server	Choose Default or Region

Table 3-7

Step 3: Click "Save" to complete the system log parameter configuration.

If you can access the Internet but fail to update the time, please try to select another NTP time server.

3.7.3 Log

Local log refers to directly viewing information such as system operation and operation configuration on the RT620 management interface. Through this information, it is possible to find abnormal conditions of the system, accurately locate problems and take effective preventive or remedial measures.

Select Administration > Log as below.

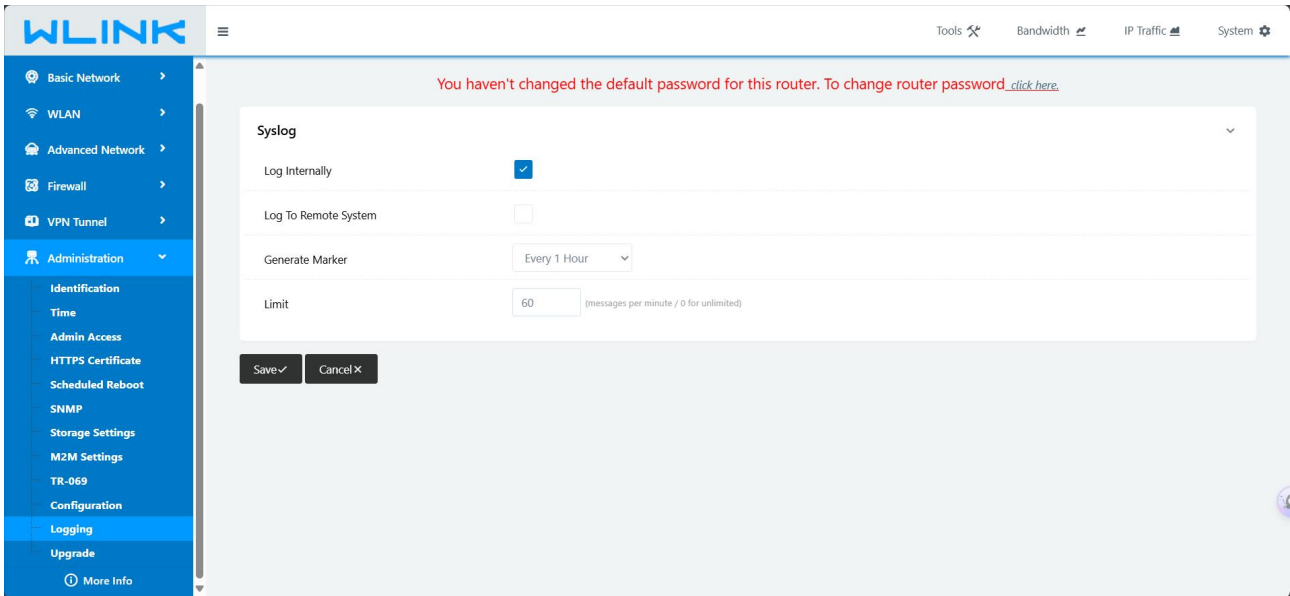

In this log configuration interface, you can choose the save path (local or remote server), and the log generation time.

After the configuration is complete, click the "Save" button to make the configuration take effect.

3.7.4 Admin Access

Choose Administration > Admin Access. In the opened page, you can modify the relevant parameters of Admin Access.

On this page, you can configure some basic web access setting items, which is convenient for users. The password setting option is to modify the password of the system account "admin".

Remote access: Enable remote access, open the corresponding port, and save it.

After the configuration is complete, click the "Save" button.

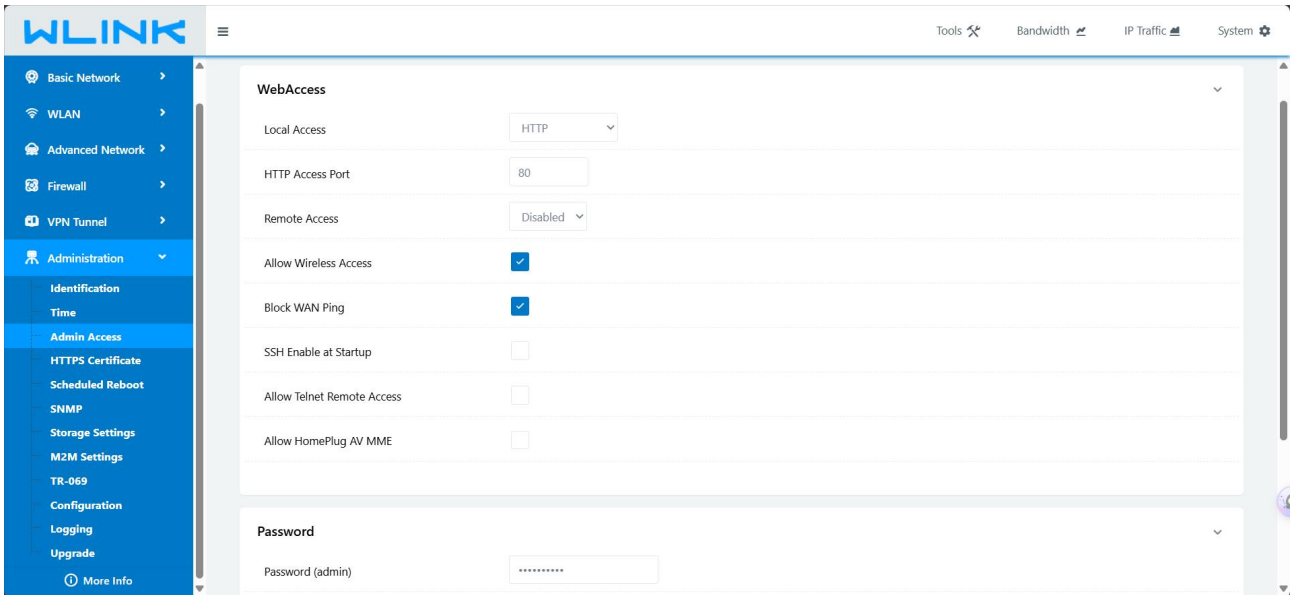

3.7.5 Upgrade

The RT620 supports local network mode for system upgrades. Ensure the latest firmware is obtained before proceeding.

- 1) Navigate to Administration > Upgrade.
- 2) Under Main Firmware Upgrade, select the new firmware file.
- 3) Enable "Erase all NVRAM data after flashing" and click [Upgrade].
- 4) Do not interrupt power or network connectivity during the process (3~4 minutes).

After completion, ping the router's IP (e.g., ping 192.168.1.1 -t). A successful response confirms the upgrade.

